

PHILIPS

Selecon

OPERATION MANUAL

SPX

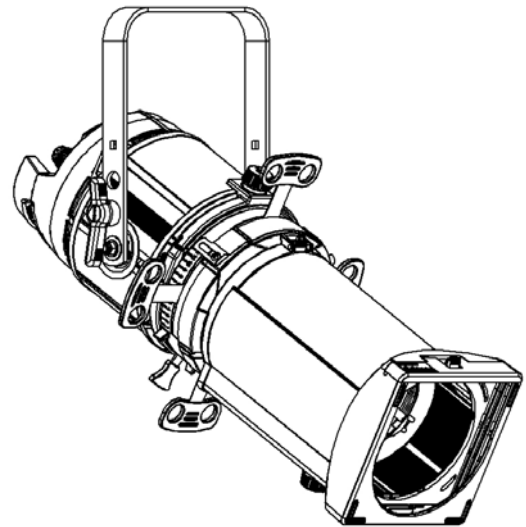

This manual covers the following models:

SPX 15° - 35° Zoomspot

SPX 25° - 50° Zoomspot

SPX 14° Fixed Beam

SPX 19° Fixed Beam

SPX 26° Fixed Beam

SPX 36° Fixed Beam

SPX 50° Fixed Beam

THANK YOU FOR PURCHASING A PHILIPS SELECON SPX LUMINAIRE. WE HAVE DESIGNED THIS LUMINAIRE TO PROVIDE YOU WITH A SUPERIOR FITTING IN PERFORMANCE, DESIGN AND ENGINEERING. WE ARE CONFIDENT THAT IT WILL PERFORM TO YOUR EXPECTATIONS FOR MANY YEARS TO COME.

Caution!

Installation is entirely at your risk. Read this manual from cover to cover before attempting installation. Do not attempt installation unless you are suitably qualified. If you do not understand a point in this manual, don't guess. Don't take short cuts. If in doubt, stop! Contact Philips Selecon or one of its authorised distributors for advice. Don't be afraid to ask for help.



IMPORTANT NOTE: The SPX sets new standards in product safety.

As it is double insulated it has a simpler testing procedure than conventional luminaires. Refer to the testing section inside.

Before discarding the packaging ensure you have the suspension bolt set, colour frame &/or the lamp.

Important!

Read this manual from cover to cover before attempting to install, operate or maintain the luminaires to which it relates. It contains important installation, operating, maintenance and safety procedures. The customer must strictly comply with them.

Along with such procedures mentioned in this document, the customer should also observe such other procedures generally applicable to lighting equipment.

Follow the instructions in this manual carefully. Philips Selecon accepts no responsibility if the customer fails to do so.

For each customer, operating conditions will vary, sometimes greatly. Such variations may affect the luminaires' performance. Philips Selecon has no control over the customer's unique operating environment. Hence, Philips Selecon makes no representations or warranties concerning the luminaires' performance under the customer's actual operating conditions. All operating parameters must be validated for each customer application by the customer's technical experts.

If the customer does not follow the installation, operating, maintenance and safety procedures in this manual, as well as those generally applicable to lighting equipment, the luminaire may not perform as expected. More seriously, it may cause property damage, personal injury or other losses.

Philips Selecon accepts no liability for direct, indirect, incidental, special, or consequential damages resulting from the customer's failure to follow the installation, operating, maintenance and safety procedures in this manual or those generally applicable to lighting equipment. The foregoing limitation extends to damages for personal injury, property damage, loss of operations, loss of profits, loss of product or loss of time, whether incurred by the customer, the customer's employees or a third party.

Philips Selecon used all due care in preparing this manual. However, Philips Selecon accepts no liability for errors or omissions. Philips Selecon reserves the right to change the specifications of its luminaires, or the information in this manual, without necessarily giving its customers notice thereof.

Installation, operation and maintenance are entirely at the customer's risk.

Philips Selecon luminaires should be installed, operated and maintained by suitably qualified personnel. Such personnel should have previous experience with lighting equipment as well as general electrical experience.

This manual is intended to provide general guidance to such suitably qualified personnel. For specific guidance and technical support, contact Philips Selecon or its authorised representative.

Information in this manual shall not be deemed a warranty, representation or guarantee concerning a luminaire's suitability or fitness for a specific purpose.

Subject to the right to use its luminaires, Philips Selecon does not convey any right, title or interest in its intellectual property, including, without limitation, its patents, copyrights and know-how.

Please read this information carefully to ensure that you are fully conversant with its operation.

Safety Warnings4

Operating your Luminaire for the First Time.....4

Centering the lamp5

Optimising the Output.....5

Lamps6

Mounting your Luminaire6

To Mount on a Theatre Standard Scaffold Pipe6

Operating your Luminaire7

Pan and Tilt Adjustment.....7

Focusing SPX Zoomspot Models7

Focusing SPX Fixed Beam Profiles.....7

Shutter System7

Shutter Lock.....7

Rotatable Shutters8

Accessory Mounting Positions.....8

Changing the Lens Tube9

Colour Filter Life9

Safe Practice10

Rigging Check-list.....10

Maintenance10

Electrical Test Procedure.....10

Cleaning the Reflector11

Cleaning the Lens.....12

Safety.....12

Limited Warranty.....13

Accessories and Order Codes.....14

Contacting Philips Selecon.....14

Safety Warnings



Not for residential use.



CAUTION: Hot Surfaces, Avoid contact by persons or materials. The SPX has some hot surfaces. Be careful to avoid burns. Take care with the lamphouse and heat-sink. We suggest the use of leather gloves when focusing these luminaires.



SAFETY – Double Insulated
The SPX range is a Class 2 appliance that is double insulated for increased safety and lower maintenance. Earth continuity testing is not needed. Refer to page 11 for testing procedure.



SAFETY - Mains Power Isolation
The SPX range is fitted with a micro-switch that automatically disconnects the mains power when the lamp holder is removed. However, it is also recommended that the luminaire should always be electrically isolated from mains power before re-lamping, cleaning or servicing.



CAUTION: Risk of fire - use with maximum 800W lamp.



CAUTION: These luminaires are not suitable for mounting on a normally flammable surface.



These luminaires are not suitable for outdoor use. They are rated at IP00.

__1.2m/4Ft 

The luminaire should be at least 1.2 metres/4 ft away from the nearest object it is lighting.

The SPX range can be operated only through a range of angles 90° either side of horizontal.

Operating your Luminaire for the First Time

Familiarise yourself with the way the shutter and reflector assembly can be rotated by loosening the rotating clamp (drawing page 9), and turning the assembly. Note how the colour frame is locked into the front of the lens tube with the front accessory cover.

The SPX provides for mounting 2 pattern holders. Practice inserting them into both the front and rear position as it is easier to familiarise yourself before rigging the luminaire.

The SPX has a shutter lock. Make sure this is in the unlocked position. Refer P.7

Lamping Procedure

Remove the lamp module by loosening the 2 locking thumbscrews on the rear. Align the pins of the new lamp to the holes in the lamp socket and push the lamp firmly home. Do not touch the quartz envelope of the lamp with your fingers. Replace the lamp module and tighten the locking thumbscrews. Reconnect the mains power. **Always take great care when making adjustments to the lamp, as its filament is fragile. N.B. The mains power supply disconnected by a microswitch as the**

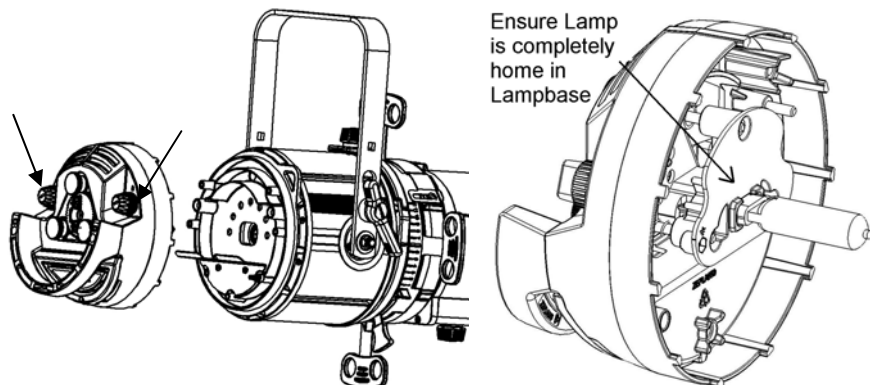

screws are loosened.

Lamp Replacement and Adjustment

Isolate electrically before re-lamping the luminaire. Also be aware that the lamp and/or luminaire may still be hot, so exercise necessary caution to avoid burns.

To ensure optimum performance from your SPX luminaire, follow the steps below:

Centring the lamp

- 1 Remove the lamp holder as described above.
- 2 Level the lamp socket plate by adjusting the lamp alignment screws.
- 3 Turn the peak/flat gear
- 4 Carefully replace the lamp holder module and tighten the thumbscrew to lock it into position. Reconnect the luminaire to the power supply.
- 5 Turn the peak/flat gear clockwise towards the peak setting. This is indicated by the raised peak setting symbol on the peak/flat gear. 5 half turns will shift the lamp into the approximate centre position.
- 6 Centre the lamp in the beam if necessary by adjusting the lamp alignment screws.

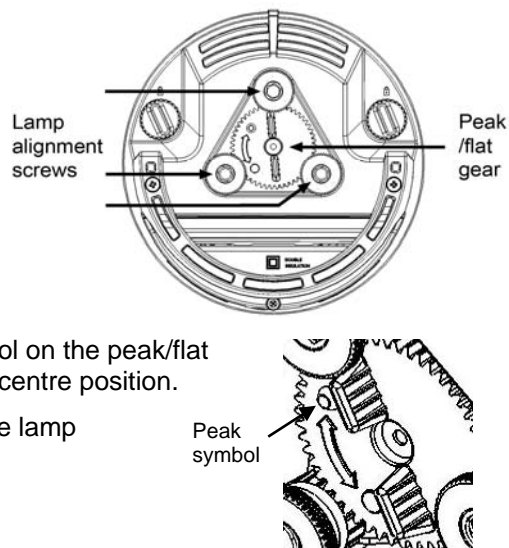

Optimising the Output

The lamp position can be altered to 'peak' or 'Flat' light output.

The peak beam gives a central hot spot falling off evenly to the beam edges. This setting is useful for normal stage lighting purposes where beams are overlapped to achieve an even cover.

Flat adjustment provides a visually even light beam suitable for gobo projection. Take care to move the lamp carefully as the lamp filament is burning white hot and at its most vulnerable.

Don't over-tighten the knobs; finger tight pressure is all that is required.

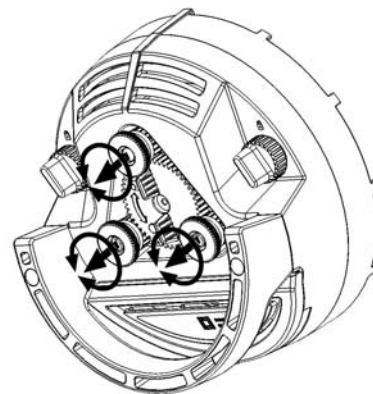

- 1 Adjust the beam to its narrow angle, with a sharp edge.
- 2 Peak the output (turn the centre gear clockwise towards the peak symbol) until you see light flare around the edge of the beam.
- 3 Turn the centre gear anti-clockwise towards the flat symbol until the flare is removed and you have a clean sharp-edged beam. This is the position of maximum light output.
- 4 A useful technique to check how well the lamp is centred is to push two of the shutters into the beam, and then check if any reflection off the shutters is visible in the beam. If so, adjust the screw on the side opposite to the reflection until it disappears.
- 5 To set a 'FLAT' beam, turn the centre gear anti-clockwise towards the flat symbol until the distribution appears even across the beam.

Lamps

The SPX range lamp module has a TP-22 (G9.5) lamp base and is designed to run with GKV range of lamps. Lamps suitable for this module include:

220-240V

GKV: 600W, 220V -240V, 300 hrs
 GLB: 600W, 240V, 1500 hrs
 GKV: 800W, 220V -240V, 300 hrs

120V

GLA: 575W, 115V, 1500 hrs
 GLC: 575W, 115V, 300 hrs
 GLD: 750W, 115V, 300 hrs
 GLE: 750W, 115V, 1500 hrs
 GLG: 375W, 115V, 300 hrs

Important note: The GKV range of lamps uses a very compact filament in order to achieve its highly efficient output. For this reason, the lamp filaments are close to each other and are therefore sensitive to shocks. Great care should be taken when adjusting the lamp and focusing the luminaire to avoid shocks.

Important Note: The quoted performance figures are achieved with Philips lamps. Other manufacturers lamps can be used, but no assumptions should be made as to relative performance.

Please refer to the instructions of the lamp manufacturer when disposing of failed lamps.

Mounting your Luminaire

A safety bond MUST always be used when rigging luminaires on bars, ladders, etc. The SPX is supplied with a rated safety bond permanently attached. This is the only recommended anchor point for the luminaire. Be careful to allow sufficient slack to allow the luminaire to be focused freely.

An extra safety bond attachment point has been provided for accessories placed in the front of the lens tube. Do not use to secure accessories weighing more than 2.5kgs / 5 ½ pounds.

The SPX uses universal burning position lamps. When possible however, it is considered best practice to mount the luminaire so the yoke is horizontal and the power cable at the bottom. Please note that the maximum tilt angles of the luminaire are 90° either side of horizontal.

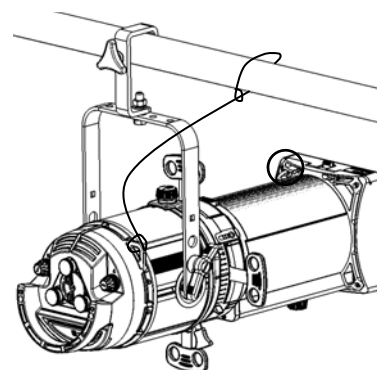

To Mount on a Theatre Standard Scaffold Pipe

(48mm O.D.) Use a theatre hookclamp (Order Code: 20HC). Your luminaire is supplied with an M12 (or ½" for North America) set screw, two washers and a nut. Pass the set screw through the yoke hole from the inside, put on a washer, then the hookclamp, another washer and then tighten the nut.

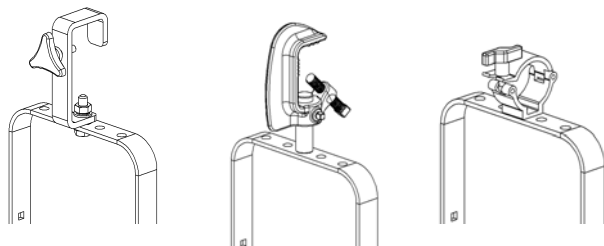

The luminaire should be at least 1.2 metres / 4ft away from the nearest object it is lighting. 1.2m/4ft

Operating your Luminaire

Please note that as the handles and knobs on the SPX range can reach high temperatures depending on the position or orientation of the luminaire, and gloves should always be worn when focusing these luminaires.

Pan and Tilt Adjustment

To pan the luminaire, loosen the nut at the top of the yoke and adjust, then retighten. To tilt, loosen the locking clamp handle on the side of the luminaire, tilt and retighten finger tight.

Focusing SPX Zoomspot Models

The beam of the SPX can be adjusted to a well controlled soft-edged focus useful when merging one beam to the next, or to a hard-edged focus useful for projections, specials, etc. The variable beam of your SPX luminaire is altered by adjusting the front or rear lens in relation to each other. The front lens defines the beam spread; the rear, the focus degree of "softness" or "sharpness" of the beam edge or shutters.

To focus your zoomspot, first define the beam size required using the front lens. Then set the hardness/ softness of the beam with the focus lens. A reference scale is on the bottom of the lens tube. The reference scale allows you to record your preferred beam settings.

Finger tight pressure only is necessary to lock the lens off in their chosen positions.

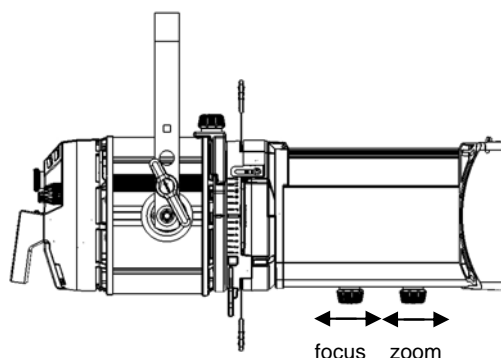

Focusing SPX Fixed Beam Profiles

The lens can be moved to adjust the beam to in focus (sharp), or out of focus (soft). A focus direction label is on the bottom of the lens tube.

To set a soft position.



focus, move the lens forward of the



hard focus

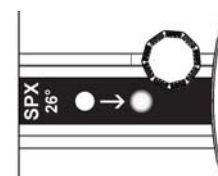

NB: If you move it too far, the beam will become unusable and may cause the colour filter to fail prematurely.

Shutter System

The shutters are used to mask a portion of the beam, shaping it, masking light off scenery, curtains, etc. Note that on the SPX range of luminaires, individual shutters are not removable.

NOTE: Do not run the luminaire with the shutters fully closed, as this may cause the luminaire to over-heat

Shutter Lock

The shutter lock is used to fix the shutters in position after they have been focused. To lock, slide the lever to the closed position. To unlock, slide the lever to the unlocked position.

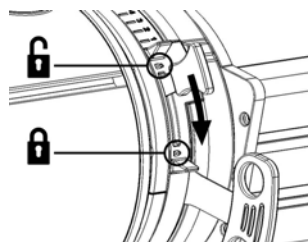

Rotatable Shutters

The shutter and reflector assembly can be rotated to position the shutters for the best cut, or to move the focus knobs into an optimum operating position.

1. Check that the front accessory cover is closed, securing the colour frame. Ensure any pattern holders or iris/ accessories are secured in the accessory slots (refer above)
2. Loosen the top shutter and reflector assembly screw clamp
3. Rotate the shutter and reflector assembly to the required position
4. Tighten the shutter and reflector assembly screw clamp.

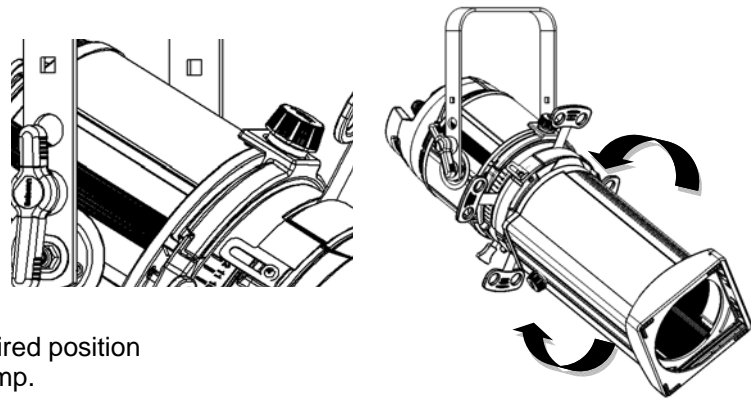

Accessory Mounting Positions

The SPX range provides good image projection right across the beam.

NOTE: The SPX range has two different pattern holders.

- SPXGHB For 'B' size steel patterns
- SPXGHGB For "B" size glass patterns



The SPX provides for mounting 2 pattern holders.

The front accessory slot will house:

- Glass pattern holder (code SPXGHB)
- An adjustable iris (code 20IRIS)
- A motorised gobo rotator (e.g. Rosco/Apollo)

The rear slot will house a Philips Selecon steel pattern holder (order code: SPXGHB).

Refer to website for a list of compatible third party accessories.

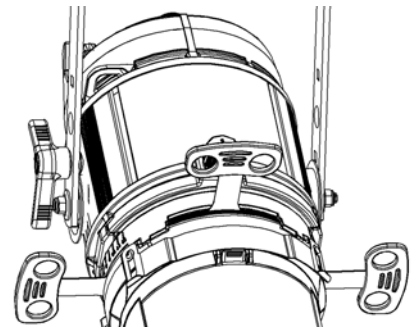

To fit an accessory in the front slot

Slide the accessory slot cover forward to reveal the aperture. Slide the accessory into the front slot. Slide the slot cover back into place to lock in the accessory. Follow the instructions of the accessory manufacturer in regards to operating and safety procedures.

To fit an accessory in the rear slot

Slide the accessory slot cover forward to reveal the aperture. Slide the pattern holder into the rear slot. Slide the slot cover back into place to lock in the pattern holder.

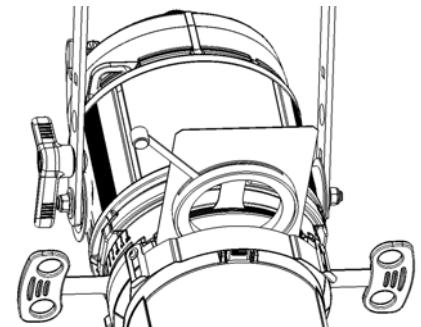

To insert an Iris

To mount the Iris (20IRIS) slide the accessory slot cover forward to reveal the aperture. Slide the iris into the front slot and push to the bottom of the slot. Slide the slot cover back into place to lock in the iris.

NB: Do not operate and adjustable iris in a ½ closed to fully closed position for extended periods of time as the heat may cause damage to iris leaves.

Changing the Lens Tube

The SPX fixed beam and zoom lens tubes are interchangeable. Move the lens knob(s) towards the front of the tube. Slide the lens tube locking catch forward and lift out the lens tube. Replace it with the desired lens tube. Ensure the lens tube locking catch is fully engaged.

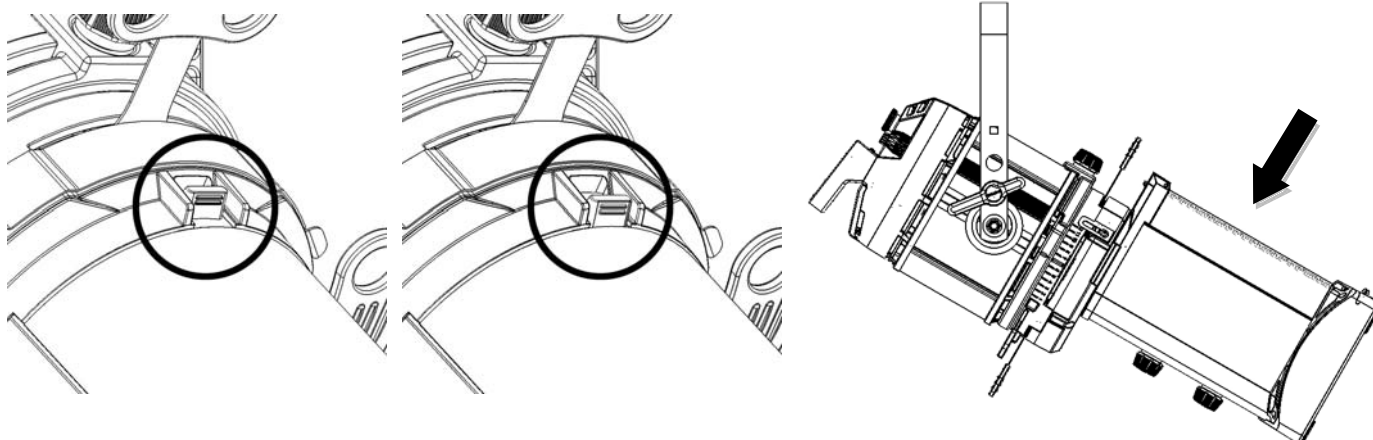

Colour Filter Life

The SPX optical system has been designed for maximum light output using modern compact filament lamps, while optimising colour filter life.

Colour filter life is of typical duration compared to other ellipsoidals.

Please refer to the table below for more performance information.

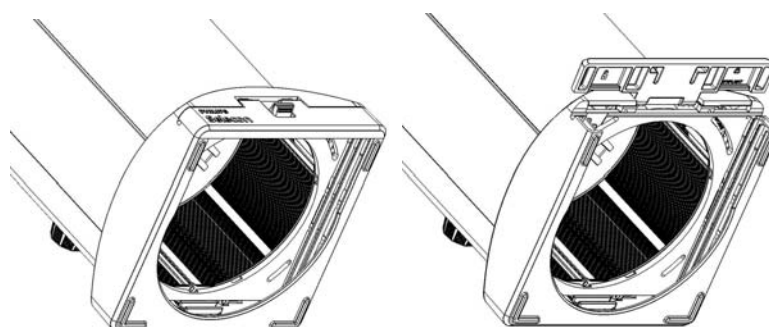

Lens Tube	Flat	Peak
14°	Excellent	Excellent
19°	Excellent	Excellent
26°	Good	Good
36°	Good	Good
50°	Good	Okay
15° - 35° at 15°	Excellent	Excellent
15° - 35° at 35°	Good	Good
25° - 50° at 25°	Excellent	Excellent
25° - 50° at 50°	Excellent	Excellent

Tested with dark blue high performance gel using an 800W lamp, 240V.

Safe Practice

Heat

The SPX incorporates an innovative design to effectively remove the heat out of the luminaire, away from the critical heat-sensitive components such as the lamp base and wiring. The components that form part of the heat removal system and lamp house will operate at temperatures which can burn you!!! Take care in handling the luminaire. We recommend the use of gloves when focusing.

Tilt Lock

Take care when releasing the tilt lock as the luminaire may suddenly swing down. Hold the lens tube with one hand and release the tilt lock with the other.

Handles

The handle on the lamp module is designed to assist positioning of the luminaire during focusing. When cold, cable can be wrapped around it for storage. Do not operate the SPX with cable wrapped around the handle.

It is also recommended that the luminaire should always be electrically isolated from mains power before re-lamping, cleaning or servicing.

Rigging Check-list

When rigging your luminaire check:

- Lens tube clamp is clipped in place correctly
- All safety anchor bonds are fitted
- Any accessories are correctly installed and secured
- Accessory cover is locked down
- The lamp module is secured in position with the lamp module locking knobs tightened.

Maintenance

Electrical Test Procedure

 *The SPX is a Class 2 Electrical appliance. It is double insulated for maximum safety and simplified maintenance. All exposed metalwork is separated from the conductors by two layers of insulation. An earth conductor is not required in a Class 2 Electrical appliance.*

Two tests must be performed on the SPX, a visual inspection and an Insulation Resistance Test for class 2 appliance. The SPX must have the Lamp Base Module correctly fitted to the luminaire in order to perform the Insulation Resistance Test.

Before performing any electrical test a suitably qualified or competent person (as defined by the standard or local laws) must first carry out a visual inspection.

- *Ensure the SPX is unplugged and at a safe handling temperature.*
- *Check that the outer casing of the SPX is not damaged in a way that will give rise to electrical or mechanical hazards.*
- *Check that the plug is not damaged.*
- *Check the electrical cable is not damaged, cable sheathing should be securely held at both the plug and the fixture and should not be cut, twisted, kinked, perished or damaged in any way and must not have been repaired with insulating tape or an unsuitable connector. The individual conductor insulation should not be exposed and wire conductor should never be visible. Check under insulation tape for damage. Damaged or defective cable should be replaced with the correct Philips*

Selecon wiring loom by a suitably qualified person. Contact your Philips Selecon distributor for more information.

Insulation Resistance Testing for class 2 appliance of the SPX is to be performed by a suitably qualified or competent person (as defined by the standard or local laws) using an ohmmeter (i.e. Megger) or portable appliance tester (PAT Machine) by applying a nominal voltage to the live conductors (active and neutral pins on plug) of the SPX, and placing a 0 volt reference probe on the external metal parts of the SPX;

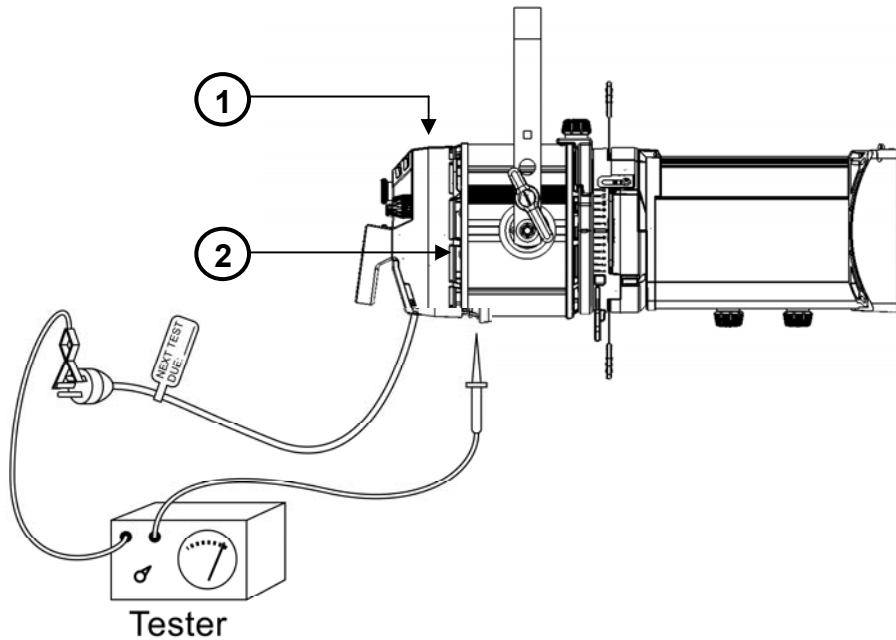

- ① Lamp module must be in place during tests
- ② Test active & neutral to accessible earthed parts

Insulation resistance limits

Equipment	Insulation Test	Minimum insulation resistance MΩ
Class II	With live and neutral conductors electrically connected measure between live parts and any accessible metal parts.	1

In accordance with AS/NZS 3760

Cleaning the Reflector

First remove the lamp module and lamp – refer page 4.

Remove the lens barrel and shutter assembly by undoing the shutter and reflector assembly rotation knob, and removing the shutter/lens assembly.

A soft cloth soaked in a mild detergent solution or alcohol can be used to remove dirt from the mirror.

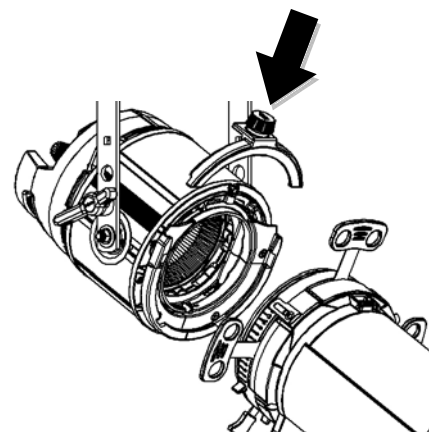

Cleaning the Lens

Remove the Lens Tube from the SPX.

Using a 3mm Allen Key, undo the retaining screws on the back and front of the tube.

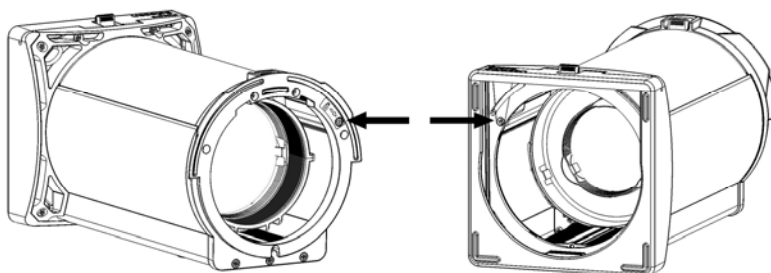

Open the top cover on the lens tube.

As the lens is multicoated, clean with a soft cloth or lens tissue only. To remove baked-on dust use a window cleaner.

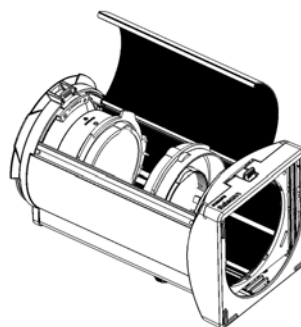

The above are the only maintenance tasks which can be safely carried out by non approved personnel. Refer below - Safety & Maintenance note.

Safety

Philips Selecon has manufactured this luminaire in accordance with recognised best practices to recommended international safety standards. It is your responsibility to maintain this luminaire in good & safe working condition.

Repairs should only be carried out by suitably qualified persons. Do not operate the luminaire with cracked lens, damaged cable, etc. Consult your Philips Selecon distributor for assistance. Only replace damaged parts with authorised Philips Selecon spares.

N.B. Luminaire Cable - Your Philips Selecon luminaire is fitted with special heat resistant flexible cable, replace with genuine Philips Selecon spare part cable kit only - refer to your Philips Selecon distributor. (Replacement cables are supplied complete with necessary terminal connectors.)

Cable Conductor colour codes:

Brown	- Phase, Live
Blue	- Neutral

As this luminaire is Double Insulated the Green/Yellow Earth wire will not be present .

Limited Warranty

Philips Selecon warrants its luminaires against defects in materials or workmanship. The term of this warranty is based on the product usage and is from the date of delivery.

Usage – Entertainment, Theatre Term - Three Years

Entertainment, Theatre relates to the typical conditions found in a theatre performance venue viz:

4 – 6 hrs per day, six days per week.

Usage – Architectural, Display Term – Three Years

Architectural, Display relates to typical usage such as display lighting in a Museum viz:

10 – 12 hrs per day, seven days per week.

Other – ALL Electromechanical / Electronic Devices Term - One Year

This warranty is void in any of the following circumstances:

- (a) The luminaire has been misused, neglected, damaged or abused.
- (b) The luminaire has been improperly installed, operated, repaired or maintained.
- (c) The luminaire has been modified.
- (d) The luminaire has been connected to other equipment with which it is not compatible.
- (e) The luminaire has been used or stored in conditions outside its electrical or environmental specifications.
- (f) The luminaire has been used for purposes other than for which it was designed.
- (g) The luminaire has been used outside its stated specifications and operating parameters.

Correct installation of the luminaire is the owner's responsibility.

To assert a warranty claim, complete Philips Selecon's return authorisation form (available from Philips Selecon). Return the luminaire to Philips Selecon or its authorised agent.

If Philips Selecon accepts the warranty claim, Philips Selecon will provide, or arrange for, service, repair or replacement as Philips Selecon shall determine in its sole discretion. Philips Selecon shall bear the cost of such service, repair or replacement. However, the owner shall bear the cost of freight and insurance on the luminaire, both ways. If Philips Selecon does not wish to service, repair or replace the defective luminaire, it shall refund the purchase price.

Philips Selecon's sole responsibility is to repair, replace or service a luminaire subject to a valid warranty claim. Under no circumstance will Philips Selecon be liable for direct, indirect, incidental, special or consequential costs or damages, including dismantling and re-installation costs, loss of operations or profits, to the maximum extent permitted by law.

Philips Selecon accepts no liability for personal injury or property damage resulting from failure to heed relevant operating and safety procedures specified by Philips Selecon or imposed by law.

This is an express warranty. Philips Selecon disclaims any other express or implied warranties, including warranties of merchantability or fitness for purpose, to the maximum extent permitted by law.

Some jurisdictions do not allow limitations or disclaimers of implied or statutory warranties. Some jurisdictions do not allow disclaimers or exclusions of consequential or incidental damages. Therefore, the above disclaimers, limitations and exclusions may not apply in all jurisdictions in which Philips Selecon sells its luminaires.

This warranty gives the owner specific legal rights. The owner may have other rights or remedies pursuant to the laws in its territory. Nothing in this limited warranty should be construed as limiting or restricting any other statutory right or remedy of the owner, except for such limitations or restrictions herein as may be allowed by the law of the territory.

Philips Selecon has a policy of continual product improvement and specifications are subject to change without notice.

Accessories and Order Codes

SPX 15° - 35° Lens tube only	SPX1535LT
SPX 25° - 50° Lens tube only	SPX2550LT
SPX 14° Lens tube only	SPX14LT
SPX 19° Lens tube only	SPX19LT
SPX 26° Lens tube only	SPX26LT
SPX 36° Lens tube only	SPX36LT
SPX 50° Lens tube only	SPX50LT
SPX 600W/800W lamp house	SPXLH
SPX 20-leaf Iris	20IRIS
SPX 'B' Pattern Holder	SPXGHB
SPX 'B' Pattern Holder – glass	SPXGHGB
SPX Lens Safety Mesh	19PACSMFB
SPX Colour Frame	19PACCF
Suspension Hook Clamp	20HC
Lamp Alignment Gear Cover	SPXPLA005
SPX Tilt Lock Kit	SPXTLOKIT

Contacting Philips Selecon

Philips Selecon

19-21 Kawana Street,
Northcote,
Auckland 1310,
New Zealand
Tel: 64-9-481 0100,
Fax: 64-9-481 0101
www.seleconlight.com

Philips Strand Lighting USA

Strand Lighting
10911 Petal Street
Dallas, TX 75238
Tel: (214) 647-7970 Support Main
Fax: (214) 647-8031

Philips Entertainment European Service & Distribution Centre

Rondweg zuid 85
Winterswijk 7102 JD
The Netherlands
Phone: +31 543 542516

Philips Entertainment Lighting Asia

Unit C, Block C 14/F
Roxy Industrial Centre
No 41-49 Kwai Cheong Road
Kwai Chung, NT
Hong Kong SAR
Tel: (852) 2796 9786
Fax: (852) 2798 6545

Please contact us, or check our web site to find the Philips Selecon distributor nearest to you.
www.seleconlight.com/distributors