

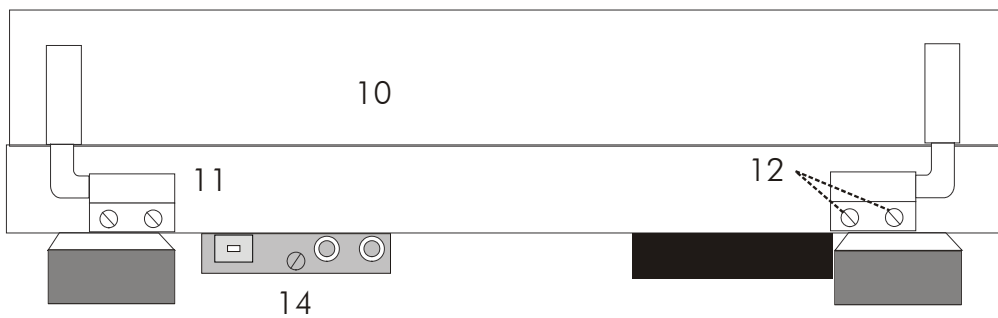

INSTRUCTIONS FOR USE
Project Debut Carbon DC Phono USB

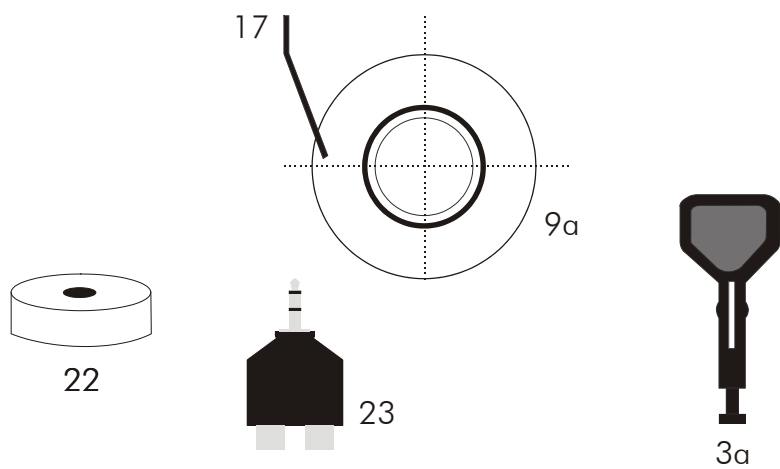
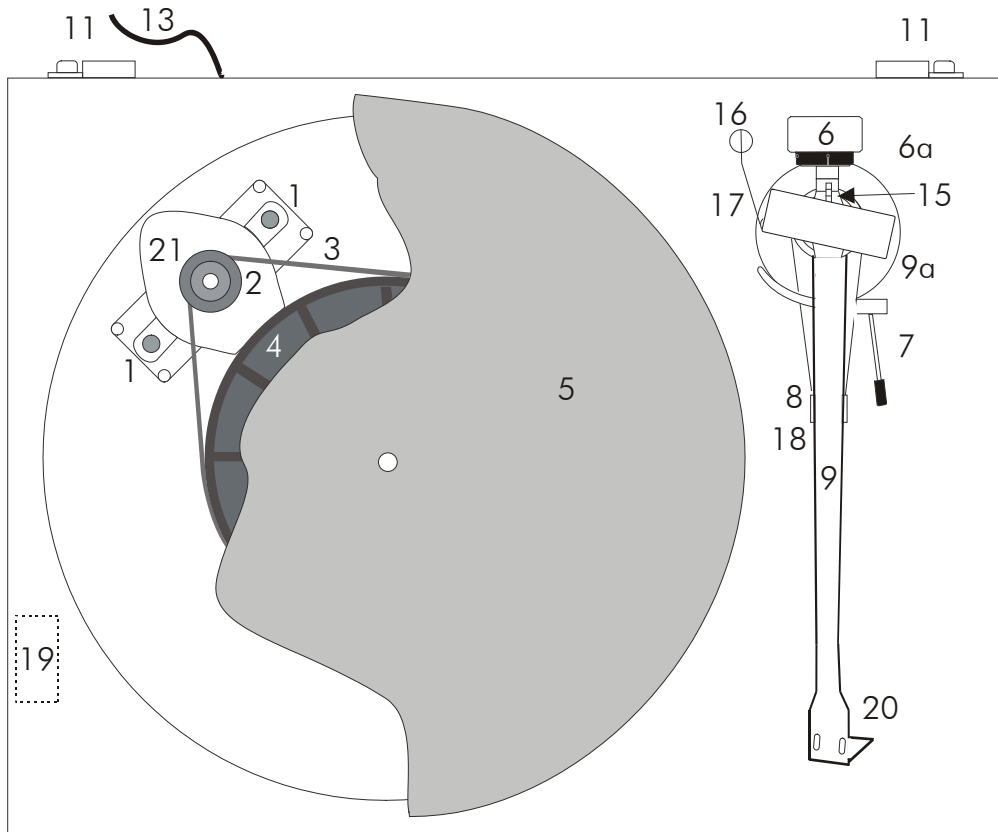

Pro-Ject Debut Carbon DC Phono USB

Controls, features and connections

1	Motor brackets with TPE (thermo plastic elastomers) pads		
2	Stepped drive pulley		
3	Drive belt *	3a	Hook *
4	Hub		
5	Platter with felt mat *		
6	Tonearm counterweight *	6a	Downforce scale
7	Tonearm lift lever		
8/18	Tonearm rest and removable transport lock		
9	Tonearm tube	9a	Tonearm base
10	Lid *		
11	Lid hinges		
12	Hinge fasteners		
13	Mains lead		
14	Phono output sockets, earth connection and USB-out		
15	Anti-skating stub with anti-skating weight adjustment scale		
16	Anti-skating weight *		
17	Anti-skating weight support hoop		
19	Power switch		
20	Headshell with finger lift and fitted Ortofon OM 10 cartridge		
21	Motor		
22	Single adapter *		
23	3,5mm connector *		
	Connection cable (not shown) *		
	Power supply (not shown) *		

Dear music lover,

thank you for purchasing a Pro-Ject Audio record player.

In order to achieve maximum performance and reliability with this record player you should study these instructions for use carefully.



Warning of a hazard for the user, the unit or possible misuse.



Important notice.

**** Your turntable has been delivered with a factory fitted and adjusted cartridge, please ignore the cartridge set up instructions unless changing the cartridge at a later date.**

During assembly and adjustment of the deck small parts could be lost if not carefully placed in a suitable receptacle. Before starting assembly make yourself acquainted with the parts listed above and correspondingly numbered in the technical drawings above. Separately packed items are marked with an asterisk *.

Safety instructions

AC outlet voltages vary from country to country. Before connecting to the mains, make sure that the voltage in your area meets the voltage requirements printed on the power supply.

The power supply is used to disconnect the unit from the mains. Make sure that the power supply is easily accessible at all times. Never handle the device, the power supply while your hands are wet or damp.



Avoid letting liquids enter the device or the power supply. Never place any item containing liquid, such as a flower vase on or near the device. Never spill any liquid on the device or the power supply. Never place any naked flame sources, such as lighted candles on or near the device. The product shall not be used in damp or wet locations, next to a bathtub, sink, swimming pool or any other similar conditions. Keep plastic bags away from children to prevent any risk of suffocation.

Set-up

The deck is supplied partially disassembled and carefully packaged for safe transport. Carefully remove all parts from the transport packaging.

Make sure the surface you wish to use the turntable on is level (use a spirit level) before placing the turntable on it.

Remove the transport lock (18) from the tonearm. Store it in the original packaging so it is available for any future transportation.

Fit the drive belt (3) around the hub (4) and the smaller diameter part of the motor pulley (2). Avoid getting sweat or grease on the belt as these will deteriorate the performance and reduce the belt's lifespan. Use absorbent kitchen paper to remove any oil or grease from the outer edge of the hub and the belt. Fit the platter (5) and felt mat over the spindle of the hub (4).

Cartridge downforce adjustment

The counterweight (6) supplied is suitable for cartridges weighing between 4,5 - 6g (weight no. **80**). An alternative counterweight for cartridges weighing between 6,5 - 8,5g (weight no. **08**) is available as an accessory part.

Pushing carefully, turn the counterweight (6) onto the rear end of the tonearm tube (9), so that the downforce scale (6a) shows towards the front of the player. Lower the armlift and position the cartridge in the space between arm rest and platter. Carefully rotate the counterweight (6) until the armtube balances out. The arm should return to the balanced position if it is moved up or down. This adjustment must be done carefully. Do not forget to remove the cartridge protection cap if fitted.

Once the arm is correctly balanced return it to the rest. Hold the counterweight (6) without moving it, and gently revolve the downforce scale ring (6a) until the zero is in line with the anti-skating stub (15). Check whether the arm still balances out.

Rotate the counterweight counter clockwise (seen from the front) to adjust the downforce according to the cartridge manufacturer's recommendations. One mark on the scale represents 1 mN (= 0,1g / 0,1 Pond) of downforce.



Please note: Adjust the downforce prior to installing the anti-skating weight.

*The recommended downforce for the factory fitted Ortofon OM 10 cartridge is **15mN**.*

Anti-skating force adjustment

The anti-skating force must be adjusted corresponding to the downforce as follows:

<u>Downforce</u>	<u>Groove in the stub (15)</u>
10 - 14mN	1 st from bearing rings
15 - 19mN	2 nd " " "
20mN and bigger	3 rd " " "

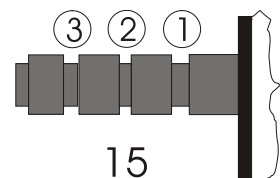

Slip the loop of the anti-skating weight's thread over the second groove of the stub to set the correct anti-skating force for the factory-fitted cartridge. Feed the thread through the loop of the wire support (17).

Fitting the lid

Fit the lid (dust cover 10) carefully over the hinge prongs and adjust the screws (12) until the lid stays open where you want it to without being too stiff to open or close.

Connection to the amplifier

The record player has gold plated female RCA phono sockets (14) so you can substitute the interconnect cables supplied with higher quality cables such as the **Pro-Ject Connect it** interconnect cables for connection to the amplifier if you wish. Use a line input (such as AUX, CD, Tuner, Tape or Video) on your amplifier.



Due to the built in phono pre-amplifier, a phono input (sometimes labelled gram, disc or RIAA) is not suitable.

Take care to connect the left and right channels correctly. The right channel is usually marked red, the left channel black or white. Check the manual supplied with your amplifier for relevant information. The earthing wire of the tonearm lead should be connected to the earth terminal on your amplifier (if provided).

For detailed product information regarding Pro-Ject Audio interconnect cables please refer to the Pro-Ject web site www.project-audio.com.



*The recommended load impedance for the factory fitted cartridges is: **47kohms/MM-input***

The 3,5 mm connector (supplied) can be used to connect your Pro-Ject Debut Carbon DC Phono USB to any line level/auxiliary input (Computer, Midi System, Mixer etc.).

Connect the socket end to the phono plugs at the end of the audio trailing lead from your turntable and insert the 3,5 mm plug into the relevant socket on your audio component.

Connecting to a Computer

Connect the USB-output of the unit to a free USB-socket on your computer and turn it on/make sure it is powered on.

The "new hardware found assistant" will automatically detect the unit and announces it as a **Microphone USB audio codec**. There is no need to install a driver manually.

After installation, one setting has to be done. For example - Windows 7® operating system:

→ Control Panel → Sound → Recording → **Microphone/USB Audio CODEC** → Properties → Advanced: set to **2 channel, 16 bit, 48000 Hz (DVD Quality)**



Please note: Connection should be made to an USB-socket of your computer directly. Connecting to USB-hubs or switches can cause problems.

Recording Programme

In case you do not have a recording programme installed on your computer, you may download one free from the Internet. Recording programmes may be found by searching Google or Yahoo.

*In the menu of the recording programme, source or input may have to be set to **Microphone USB audio codec**.*



Please be aware that downloads from the Internet are made entirely at your own risk. Under no circumstances can we carry responsibility or provide support for third-party software products sourced from the internet or for any damage or problems arising from the use thereof. All downloads should be checked with an up-to-date anti-virus programme. License fees may be applicable.

Mains power connection

Connect the low voltage plug from the power supply to the socket (13) on the rear of the record player before connecting the power supply to the mains.



Never use any other power supply than the one supplied with the unit.

Useful tips

The record player should be positioned on a low-resonance surface such as wood or multiple layer ply board to avoid structural vibrations disturbing replay.

Switching on and off

Pressing the power switch (19) alternately starts or stops the motor.

Changing replay speed

To play records at 45 r.p.m. first remove the platter (5). Using the accessory tool provided (3a), hook the belt (3) over the larger diameter part of the motor pulley (2). Refit the platter. To revert to 33 r.p.m. repeat the proceedings using the smaller step on the pulley.

Fitting and connecting the cartridge

** All cartridges with half inch mounting holes can be fitted. Leaving the needle's protection cover on, fit the cartridge to the headshell using the screws supplied with the cartridge by passing one screw through each slot in the headshell (20). Do not tighten the nuts yet.

Connect the tonearm wires to the cartridge pins as follows:

white	left channel positive (L+)
red	right channel pos. (R+)
green	right channel return (R -)
blue	left channel return (L -)

The full sound quality of the record player can only be achieved if the cartridge is correctly adjusted. Particular tools like the Pro-Ject alignment tool are required to accomplish this job properly.

If you are not well acquainted with the adjustment of cartridges you are advised to call upon the willing help of your Pro-Ject dealer to accomplish this task for you.

 *Please note: Adjusting a cartridge and tonearm calls for the greatest care in order to avoid damaging the cartridge or tonearm bearings. Leave this work to your dealer if you are in any way unsure of the necessary steps and precautions to be taken.*

Adjusting the azimuth

** The cartridge needle must be vertical in the record groove in order to trace the groove wall modulations correctly.

A small screw at the bearing end of the arm allows incorrect azimuth to be corrected if your needle is not mounted exactly perpendicular to the cartridge body (which is often the case).

Slacken off the screw just enough to be able to revolve the arm tube without applying force. Please note: do not remove the screw completely!

With the aid of a good magnifying glass adjust the needle until it is vertical in the groove (i.e. perpendicular to the record's surface). Ideally this should correspond to the top surface of the cartridge body being parallel to the record surface.

When you are satisfied that the needle is vertical retighten the screw carefully.

 *Please note: Under no circumstances should the arm tube be adjusted with the needle still in the record groove! Irreparable damage may be caused to the cantilever suspension! The arm must be lifted to make each adjustment and lowered afterwards to check it.*

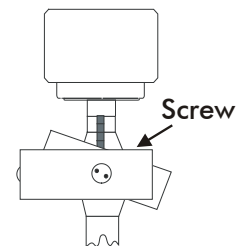

Maintenance and cleaning

Your record player requires little or no regular maintenance. Remove dust with a slightly moistened antistatic cloth. Never use a dry cloth because this will create static electricity which attract more dust! Antistatic cleaning fluids are available at specialist stores but must be applied sparingly to avoid damage to rubber parts. It is recommended to fit the needle cover before cleaning or maintenance is carried out to avoid damage.

If the player is not used over a long period of time the drive belt can be removed to prevent unequal stretching.



Always disconnect the record player from the mains power supply as a precaution before maintenance!

Technical specifications Pro-Ject Debut Carbon DC Phono USB / Pro-Ject 8.6cc

Nominal speeds	33/45 r.p.m.
Speed variance	33: $\pm 0,60\%$ 45: $\pm 0,70\%$
Wow and flutter	33: $\pm 0,19\%$ 45: $\pm 0,17\%$
Signal to noise	68dB
Effective tonearm mass	6g
Effective tonearm length	8,6 " (218,5mm)
Overhang	18,5mm
Power consumption	4W/0W in Stand-By
Outboard power supply	15V / 0 – 0.8mA DC (set at 0.5mA), universal power supply
Dimensions (W x H x D)	415 x 118 x 320mm, dust cover open 415 x 365 x 405mm
Weight	6,0kg
Dimensions packaging (W x H x D)	488 x 235 x 393mm
Weight incl. packaging	8,0kg

Technical specifications moving magnet phono pre-amplifier - A/D converter

* typical for MM or high output MC cartridges

Input capacitance/input impedance	47kohms/100pF *
Gain	32dB
Output voltage typically	200mV/1kHz at 5mV
Noise floor	-88dB
RIAA-equalisation curve accuracy	20Hz-20kHz / max. 0,5dB
USB output	digital serial data protocol USB 1.1
Operating systems	Windows XP®, Windows VISTA®, Windows 7®, Windows 8®, Mac OS

Technical specifications MM-Cartridge Ortofon OM 10

Frequency range	20-22.000Hz
Channel separation	22dB/1kHz
Output voltage	4mV
Recommended load impedance	47kohms/amplifier connection – MM-input
Compliance/stylus type	25 μ m/mN – elliptical
Recommended tracking force	15mN
Weight	5g

Potential incorrect use and fault conditions

Pro-Ject turntables are manufactured to the highest standards and undergo strict quality controls before leaving the factory. Faults that may possibly occur are not necessarily due to material or production faults but can sometimes be caused by incorrect use or unfortunate circumstances. Therefore the following list of common fault symptoms is included.

The platter doesn't turn although the unit is switched on:

- The unit is not connected to the mains power supply.
- No mains at the socket.
- Drive belt is not fitted or has slipped off.

No signal through one or other channel or both channels:

- No signal contact from the cartridge to the internal tonearm wiring or from that to the arm lead or from that to the phono box or between that and the amplifier. This could be due to a faulty plug, broken wire or solder joint or simply loose plug/socket connection.
- Wrong input selected at amplifier.
- Amplifier not switched on.
- Amplifier or speakers defective or muted.
- No connection to the loudspeakers.

Distorted or inconsistent sound from one or both channels:

- Record player is connected to wrong input of amplifier, or MM/MC switch incorrectly set.

Needle or cantilever damaged.

Wrong r.p.m., drive belt overstretched or dirty, platter bearing without oil, dirty or damaged.

Service

Should you encounter a problem which you are not able to alleviate or identify despite the above information, please contact your dealer for further advice. Only when the problem cannot be resolved there should the unit be sent to the responsible distributor in your country.

Guarantee repairs will only be effected if the unit is returned correctly packaged. For this reason we recommend keeping the original packaging.

Never return a record player without making sure that it is safely disassembled and correctly packaged in the original packaging according to the diagrams on the last page of this user guide. Please remove these parts and pack them separately: lid (10), counterweight (6), anti-skating weight (16) platter (5) and belt (3). Fit the cartridge protection cap. Insert the transport lock for the tonearm (18) prior to carefully packaging the record player.

Warranty



The manufacturer accepts no responsibility for damage caused by not adhering to these instructions for use and/or by transportation without the original packaging. Modification or change to any part of the product by unauthorized persons release the manufacturer from any liability over and above the lawful rights of the customer.

Copyright, trademarks

PRO-JECT is a Registered Trademark of H. Lichtenegger.

This guide was produced by: Pro-Ject Audio Systems
Copyright © 2012. All rights reserved.

The information was correct at the time of going to press. The manufacturer reserves the right to make changes to the technical specification without prior notice as deemed necessary to uphold the ongoing process of technical development.

Windows XP®, Windows Vista®, Windows 7®, Windows 8® are trademarks of the Microsoft group of companies.
Mac and Mac OS are trademarks of Apple Inc., registered in the U.S. and other countries.

