

# **VS SERIES**

PROFESSIONAL POWER AMPLIFIERS

**VS-450 / VS-600 / VS-4250**

USER MANUAL



## IMPORTANT SAFETY PRECAUTIONS AND EXPLANATION OF SYMBOLS

- 1- Read these instructions.
- 2- Heed all warnings.
- 3- Follow all instructions.
- 4- **WARNING:** To prevent fire or electric shock, do not expose this equipment to rain or moisture. Do not use this apparatus near water.
- 5- Clean only with a dry cloth.
- 6- Do not block any ventilation openings. Install in accordance with the manufacturer's instructions.
- 7- Do not install near any heat sources such as radiators, heat registers, stoves, or other apparatus (including amplifiers) that produce heat.
- 8- This apparatus should be connected to a receptacle with a protective earthing (or ground) connection.
- 9- Protect the power cord from being walked on or pinched, particularly at plugs, convenience receptacles, and the point where they exit from the apparatus.
- 10- Use only attachments/accessories specified by M PRO SYSTEMS.
- 11- Use only with hardware, brackets, stands, and components sold with the apparatus or by M PRO SYSTEMS.
- 12- Unplug the apparatus during lightning storms or when unused for long periods of time.
- 13- Refer all servicing to qualified service personnel. Servicing is required when the apparatus has been damaged in any way, such as power supply cord or plug is damaged, liquid has been spilled or objects have fallen into the apparatus, the apparatus has been exposed to rain or moisture, does not operate normally, or has been dropped.



The exclamation point within an equilateral triangle is intended to alert the user to the presence of important operating and maintenance (servicing) instructions in this manual.



The lightning flash with arrowhead symbol within an equilateral triangle is intended to alert the user to the presence of uninsulated "dangerous" voltage within the product's enclosure that may be of sufficient magnitude to constitute a risk of electric shock to humans.



**CAUTION:** TO REDUCE THE RISK OF ELECTRIC SHOCK, DO NOT REMOVE THE COVER. NO USER-SERVICEABLE PARTS INSIDE. REFER SERVICING TO QUALIFIED PERSONNEL.



**WARNING:** To prevent fire or electric shock, do not expose this equipment to rain or moisture.

## **INTRODUCTION**

Thank you for purchasing an M PRO SYSTEMS Power Amplifier. The VS Series is consisted of power amplifiers, designed to produce the best possible results for a wide range of users. In most cases you can plug and play with no surprises, but for best results we recommend you review and observe the enclosed user guide before operating this equipment.

Please remove the M-PRO Power Amplifier from its packaging. It is best to keep the carton in case the amplifier needs to be returned, at least until it has been tested. Check before initial operation to make sure that the device has not been visibly damaged during transport. If you detect any damage to the power cable or the casing, do not operate the device. Contact your local dealer.

## **SUPPORT AND SERVICE**

M-PRO SYSTEMS maintains a wide network of dealers and service centers. These local agencies will be able to answer your questions and take care of any problems.

### **M Pro Systems website**

Our website, [www.mprosystems.de](http://www.mprosystems.de), is factory-maintained and supported in multiple languages. Visit frequently for new announcements, typical questions, and other user information.

## **IMPORTANT SAFETY PRECAUTIONS**

The products of M Pro Systems are designed for safe operation, and have been certified by recognized product safety agencies to meet all normal standards for this type of product. However, dangerous voltages and power levels exist within the covers of this amplifier. The user is requested to study the precautions in this manual. If the product has been dropped, dented, soaked, or appears to have loose parts inside, the risk of shock is increased. Unplug the AC cord, and take the product to qualified service personnel for inspection and repairs.

## **POWER RATING**

<b>MODEL</b>	<b>80HMS</b>	<b>40HMS</b>	<b>20HMS</b>
<b>VS-450</b>	2x250W	2x450W	2x650W
<b>VS-600</b>	2x350W	2x600W	2x800W
<b>VS-4250</b>	4x150W	4x250W	-

## FEATURES

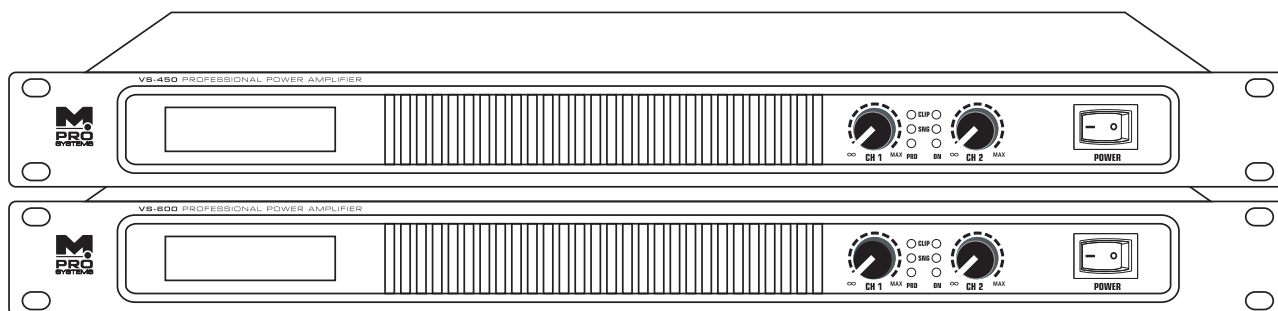

### VS-450 / VS-600

- 2 channel Class D type, SMPS Power amplifiers ideal for touring as well as permanent installations
- Optimized for maximum real-world headroom into 2Ω, 4Ω and 8Ω speaker systems.
- Inputs: XLR (IN/ LINK OUT)
- Outputs: Speakon accepts Speakon 2-pole and 4-pole plugs (connects 2 poles only).
- 19" 1U Rackmount chassis
- LCD liquid crystal display showing each channel volume level and operating temperature

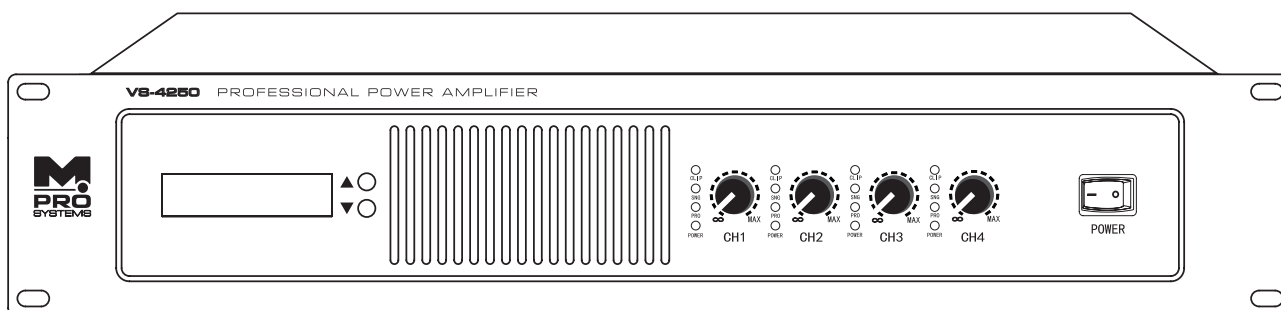

### VS-4250

- 4 channel power amplifier ideal for touring as well as permanent installations
- Optimized for maximum real-world headroom into 4Ω and 8Ω speaker systems.
- Inputs: XLR / 1/4" TRS and RCA inputs
- Outputs: Speakon accepts Speakon 2-pole and 4-pole plugs (connects 2 poles only). Binding posts support all other speaker wiring systems
- 19" 2U Rackmount chassis
- LCD liquid crystal display showing each channel volume level and operating temperature

## FRONT PANEL FEATURES

### VS-450 / VS-600

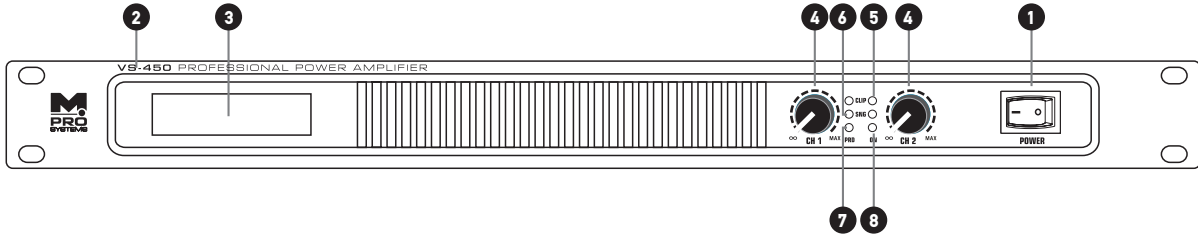

### VS-4250

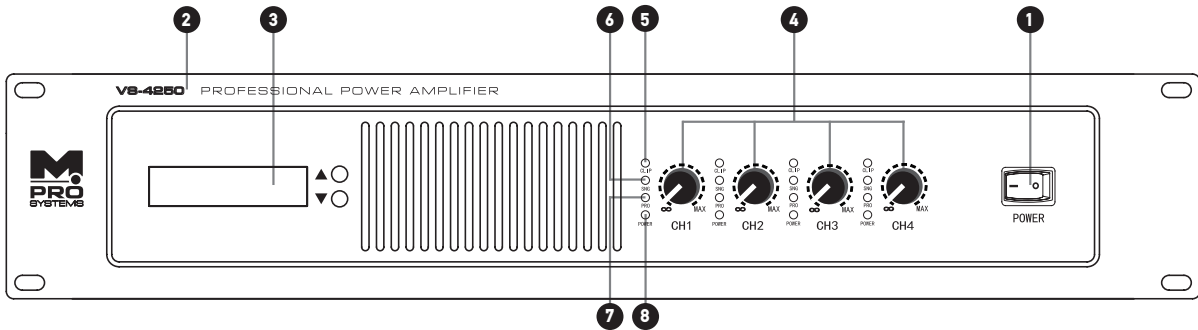

#### 1. ON/OFF Switch

**2. Model Number** The power ratings are shown on the Specifications page

**3. Led Display** Shows each channel volume level and operating temperature. Minor variations of up to 3% on volume levels between channels are acceptable and considered as normal.

**4. Gain Controls** Ch1, Ch2, Ch3, Ch 4 (Ch 3-4 Exist only for VS4250)

Turn the Gain controls clockwise to increase Gain and counterclockwise to decrease Gain. For normal use, keep control in the upper half of its range. If set below half, the source may overload before the amplifier reaches full power.

#### Attention!

**Continuously operating at high levels may trigger the thermal protection circuitry, shutting down the amplifier and fully illuminating the protect indicator. Operation will resume after the amplifier has cooled down sufficiently.**

**5. Red clip leds** Red flashing indicates the amplifier is being overdriven. The led's brightness indicates the amount of distortion. During muting, the indicator fully illuminates. This occurs during normal ON/OFF Muting.

- When the red led remains on continuously it is either because of the thermal muting or a shorted output.

- If the amplifier overheats, and the red led is on, indicates that the temperature is over 80 °C

- A shorted or overloaded output circuit causes excessive clip flashing and possible overheating.

- If distortion is noticeable without clip indicator, the problem should be either before or after the amplifier. Check for faulty speakers or signal source.

**6. Green Signal leds** The green LED starts flashing on soft signals (-35 dB), and changes to steady green as the signal level increases.

- If the green signal led is off, check gain settings and increase Gain if necessary.

**7. Protect led (PRO)** Single red led indicates that the amplifier goes into protective muting. Under normal operation the led is off.

**8. Power led (POWER)** Single green led indicated that the AC switch is on, and the amp is receiving power. Within two seconds, it is ready to use.

## REAR PANEL FEATURES

### VS-450 / VS-600

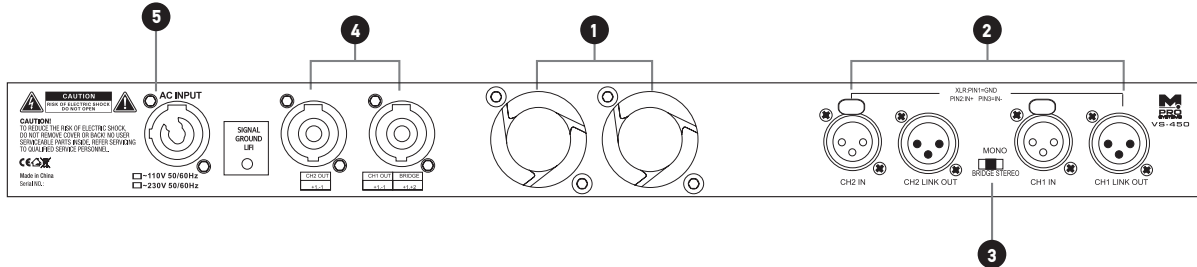

- 1. Cooling system:** Keep ventilation clean. Install in open-back rack.
- 2. Input connections:** Balanced XLR inputs: Pin 2 Positive, Pin 3 Negative, Pin 1 Shield (Ground). Recommended for long or short runs, either fixed or frequently changed. Each channel's XLR in and LINK out are connected internally, and provide feed thru to the other connector.
- 3. Stereo / Bridge mono mode:** The amplifier can be set for normal Stereo operation or Bridge mono mode. In stereo mode each channel remains independent. The amplifier may be used for two different signals. In bridge mode, both channels are combined into one channel with twice the output power. Use only the first channel's input and Gain control. Set the second channel's control to minimum.
- 4. Output connections:** Speakon cables (2 wire type): Insert and turn until the connector clicks. Use the thumb latch or locking ring to release the plug. When bridge mode: Connect to CH1 Bridge mode using pins +1 +2
- 5. AC Input interface**

### VS-4250

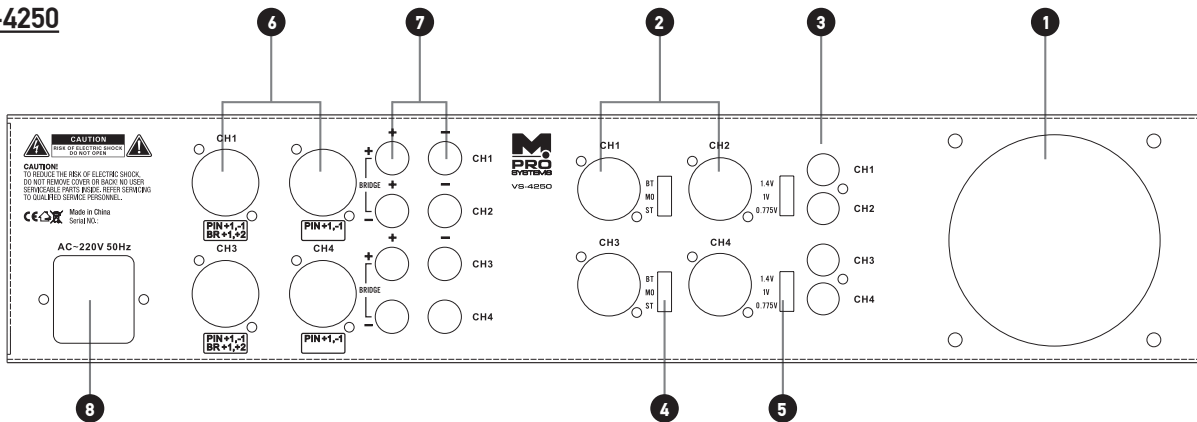

- 1. Cooling system:** Keep ventilation clean. Install in open-back rack.
- 2. Combo Balanced Inputs XLR/TRS:** Recommended for long or short runs, either fixed or frequently changed.
- 3. Unbalanced Phono Inputs:** Tip Positive, Barrel Shield (Ground). Recommended for semi-permanent connections to nearby sources, within the same rack. NOTE: when using these inputs, the TRS or XLR inputs should not be used.
- 4. Stereo / Bridge mono mode:** The amplifier can be set for normal Stereo operation or Bridge mono mode. In stereo mode each channel remains independent. The amplifier may be used for four different signals. In bridge mode, Ch1 & 2 are combined into one channel with twice the output power. Ch 3 & 4 are combined to one channel as well. Use only the first channel input and Gain control of each group (Ch1 for bridge mode 1&2, Ch3 for bridge mode Ch3&4). Set the second channel's control to minimum.
- 5. Input sensitivity:** adjust switch (one for CH1 & 2, one for CH3 & 4).
- 6. Speakon Cables (2 wire type):** Insert and turn until the connector clicks. Use the thumb latch or locking ring to release the plug. When bridge mode: Connect to CH1 and CH3 Bridge mode using pins +1 +2.
- 7. Binding Posts:** Accepts bare wires or terminals may be inserted into the side holes. Red is positive pole and black is negative pole. When use in bridge mode for Ch1 use Ch1 red as positive pole and Ch2 red as negative pole, for Ch3 use Ch3 red as positive pole and Ch4 red as negative pole.
- 8. AC Input interface**

## TROUBLESHOOTING

### NO POWER, NO LIGHTS, NO FAN

Confirm that the AC cord is fully seated and connected to a live outlet. Check the AC source by trying another device such as a lamp.

### AMPLIFIER SOUNDS DISTORTED.

If the red clip led is flashing, the amplifier is being played beyond its normal rated power. The auto protection will reduce volume somewhat to prevent severe overdrive, but if the input signal is further increased, the limiter can be overridden, with increased distortion.

If the speakers or speaker cables are shorted or defective, the amplifier may distort at lower-than-normal levels, with increased flashing of the red clip led. This should be checked by trying an alternate speaker and cable.

If the sound is distorted or garbled without flashing the red clip led, the distortion is not occurring inside the amplifier. Either the speaker is bad or the input signal is distorted.

- Confirm that the speaker is OK by trying a different unit.
- Input overload can occur if the amplifier Gain controls are set too low, and the input source is overdriven to compensate. Reduce the source volume until the distortion clears up, and increase amp Gain to reach the desired level. It is generally desirable to keep the amp gains at or near their full, clockwise, position.
- Check all input connections. Do not plug two different sources into the same channel. Use a mixer to blend sources.

### NO SOUND, WITH POWER LED ONLY, NO GREEN OR RED LED

Confirm that the Gain controls are turned up. Confirm that the input cables are correctly installed at both ends. Confirm that the source is active. If necessary, try another source, or connect another amplifier to the existing source.

### NO SOUND, BUT THE GREEN LED IS RESPONDING

The green LED indicates the amp is producing a signal, so sound should be heard if the speaker is connected. Check the speaker connections at both ends, and try a different speaker.

### NO SOUND, RED LED ON

If the amp overheats severely, it will mute until it cools off. The fan will be running at full speed, and sound should resume in less than a minute. If the amp feels hot and the fan is not running, it needs to be serviced.

### BACKGROUND HUM

Balanced XLR or TRS cables are better for long runs. Hum can be a problem when connecting to TV-cable rigs, since the TV cable often creates a ground conflict. Request or install a TV cable isolator to reduce this problem.

Hum can also occur earlier in the signal chain, depending on the types of connections. It often helps to plug everything into the same AC strip, if the total power consumption is not excessive.

As a last resort, mild hum can sometimes be reduced by lowering the amp gain, and increasing the source gain to compensate, but you must ensure that the source can deliver the extra volume without overload distortion. If this does not reduce hum, it is coming from the source.

### AMPLIFIER NEEDS SERVICING

The following conditions indicate possible unsafe conditions that require service before using. If observed, unplug the AC cord from the wall and when safe, remove the amp for servicing.

- If the amplifier emits smoke or burning smells
- If the case is severely dented or deformed
- If the amplifier is soaked with any fluid
- If internal parts sound loose
- If the amplifier is dropped, carefully inspect for damage or loose parts before attempting to use.



**SPECIFICATIONS***Specification subject to change without notice*

MODEL	VS450	VS600	VS4250
Channels	2	2	4
Output power 80hm	2x250W	2X350W	4X150W
Output power 40hm	2x450W	2x600W	4x250W
Output power 20hm	2X600W	2x800W	-
Bridge mode 40hm	600W	750W	2x300W
Input Sensitivity	1,23Vrms	1,23Vrms	0,775V/1V/1,4V
Signal to Noise (30Hz – 20kHz)	100dB	100dB	100dB
Output Circuitry	Class D	Class D	Class B
Distortion	<0,02%	<0,02%	=<0.1%
Frequency response	30Hz-20kHz	30Hz-20kHz	202Hz-20kHz
Input impedance	20kOhm Balanced, 10kOhm unbalanced		
Input connectors, each channel	3-pin XLR	3-pin XLR	3-PIN XLR/TRS 1/4", RCA unbalanced
Output connectors, each channel	Speakon	Speakon	Speakon, Binding posts
Amplifier and Load protection	Short circuit, open circuit, thermal		
Controls and indicators, front panel	AC Power switch, Gain controls, Red clip leds, Green Signal Leds		
Controls, Rear panel	Stereo / Bridge switch, Input sensitivity switch (only on VS4250)		
Dimensions (WxDxH) mm:	483x225x44	483x225x44	483x310x88
Rackmount:	19" 1U	19" 1U	19" 2U
Weight:	4,14kg	4,14kg	17,50kg

## WARRANTY

### Disclaimer

M PRO Systems, is not liable for any damage to amplifiers or any other equipment that is caused by negligence or improper installation and/or use of this loudspeaker product.

### M PRO SYSTEMS 3 Year Limited Warranty

M PRO SYSTEMS guarantees its products to be free from defective material and / or workmanship for a period of three (3) years from date of sale, and will replace defective parts and repair malfunctioning products under this warranty when the defect occurs under normal installation and use - provided the unit is returned to one of our authorized service stations via prepaid transportation with a copy of proof of purchase (i.e., sales receipt). This warranty provides that the examination of the return product must indicate, in our judgment, a manufacturing defect. This warranty does not extend to any product which has been subjected to misuse, neglect, accident, improper installation, or where the date code has been removed or defaced. M Pro Systems shall not be liable for incidental and/or consequential damages. This warranty gives you specific legal rights. This limited warranty is freely transferable during the term of the warranty period. In the event that this product was manufactured for export and sale outside of the Greek Region, then this limited warranty shall not apply. Removal of the serial number on this product, or purchase of this product from an unauthorized dealer, will void this limited warranty. Periodically, this warranty is updated. To obtain the most recent version of M Pro Systems' warranty statement, please visit [www.mprosystems.de](http://www.mprosystems.de) or contact your local dealer.

## HOW TO CONTACT M PRO SYSTEMS

Ludwigstrasse 13, 95126 Schwarzenbach an der Saale, Germany  
email [info@mprosystems.de](mailto:info@mprosystems.de)

[www.mprosystems.de](http://www.mprosystems.de)



# VS SERIES

PROFESSIONAL POWER AMPLIFIERS



Ludwigstrasse 13, 95126 Schwarzenbach an der Saale, Germany  
email [info@mprosystems.de](mailto:info@mprosystems.de) [www.mprosystems.de](http://www.mprosystems.de)

